

NBN Power Supply with Battery Backup Battery Specification

Print this page and take it to the battery retailer to ensure the battery you buy meets the correct specifications for the NBN Power Supply with Battery Backup.

Battery type: 12V 7.0-7.2Ah 6 Cell VRLA Sealed Lead Acid Battery

Dimensions: 150mm (W) x 94mm (H) x 64mm (D)

Terminals: Quick Disconnect F2
6.35mm (W) x 0.81mm (T) Faston®Tab terminals.

These are to be located 8mm from the side edge of the battery casing and 12-24 mm from the top edge of the battery casing, as indicated right. Only batteries that have terminals in these exact locations will function.

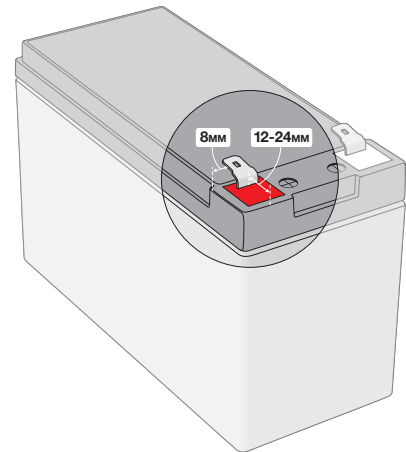

The following information may be useful for retailers that offer in-home battery replacement services.

Identifying the NBN Power Supply with Battery Backup

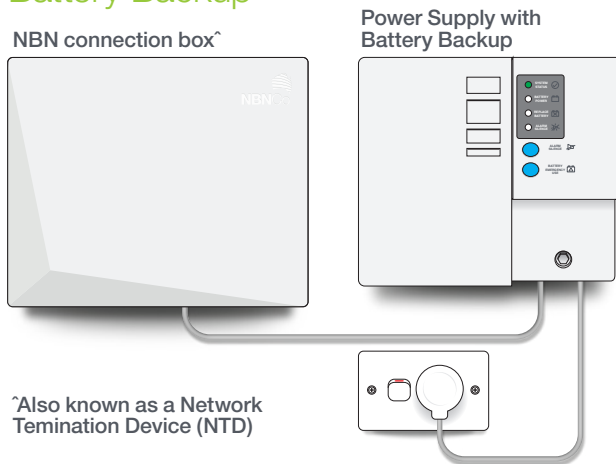

Location of battery

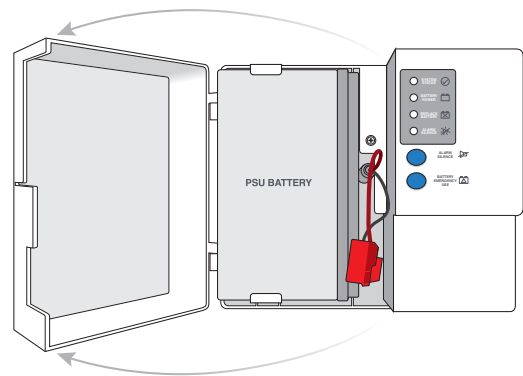

Replacement of the battery

Follow the detailed battery replacement instructions in the NBN Fibre User Guide which can be found inside the NBN connection box enclosure or at www.nbnco.com.au/fibreuserguide



For your own safety, never perform maintenance on your power supply with battery backup (including disconnecting or replacing the battery) without first reading the detailed instructions in the fibre user guide.